

MAGNETIC PARTICLE CLUTCH C2 - M

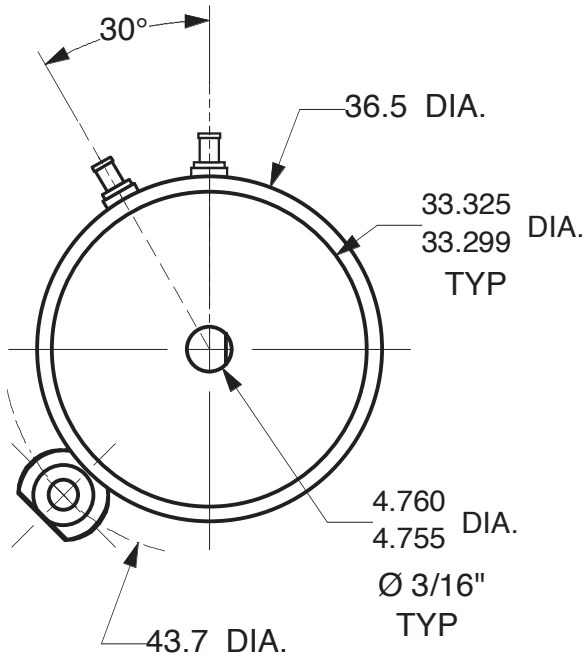

3 CLAMPS,
USE M3-0.5 X 10mm SCREW

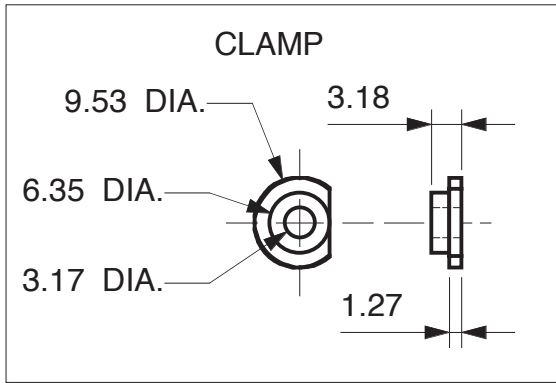
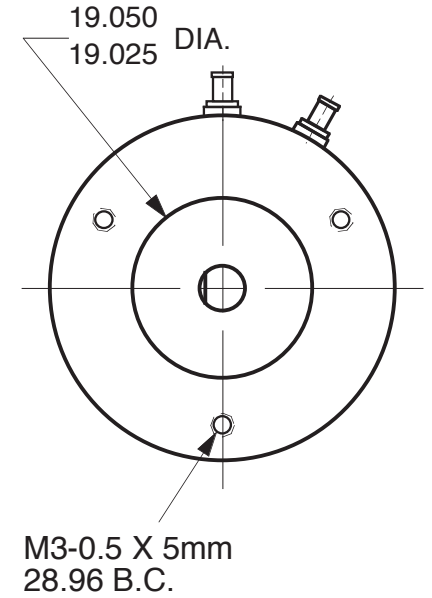
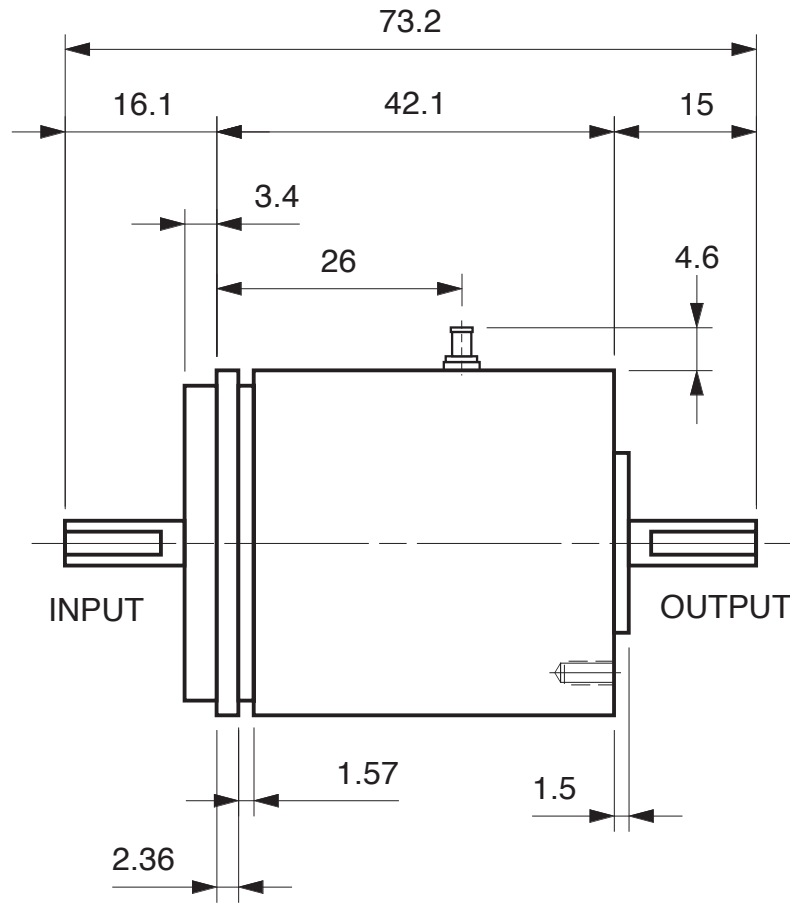

Units : mm
Scale : 1.25 x

Drawn 9/27/01
Changed 9/27/01

Elmira, NY 14901 USA
Telephone: 518-523-2422
www.placidindustries.com

