

POWER SUPPLY

MODEL: PS - (voltage) - MC

Specify 12 or 24 Volts D.C.

The power supply is suitable for Placid Industries brakes up to 220 lb.-in. & clutches up to 130 lb.-in. torque. The power supply is a constant current type, with a 3/4 turn potentiometer for setting output current from 0% to 100%. The output current can also be controlled with a 0-10 Volt Input Signal or Follower Arm Potentiometer. The SPAN adjustments set maximum and minimum current levels.

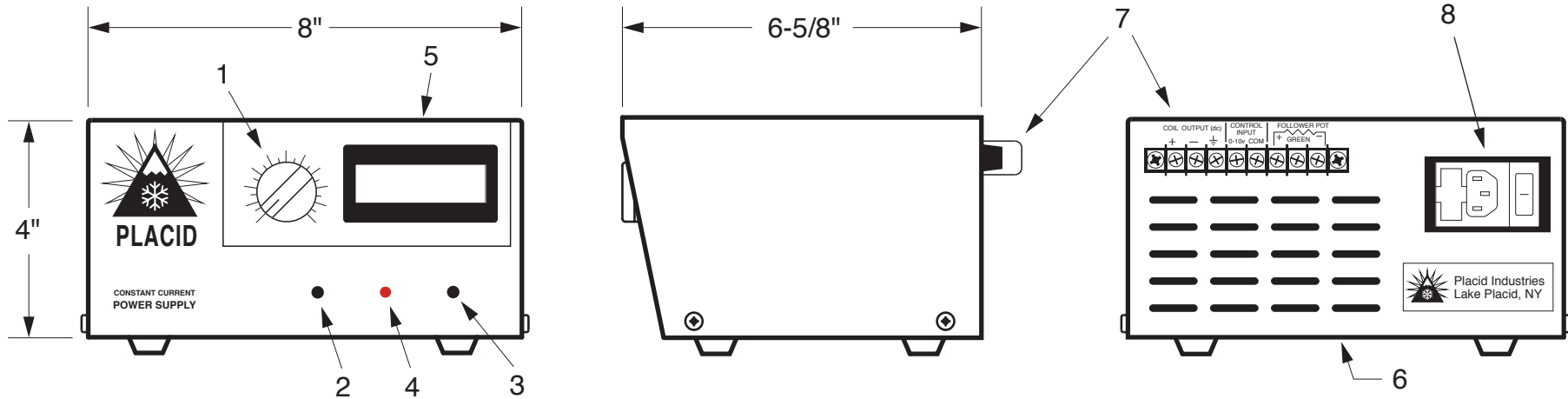

1. % RATED CURRENT potentiometer
2. Current SPAN MAX. potentiometer
3. Current SPAN MIN. potentiometer
4. LED 'Power On' light
5. L.C.D. digital ammeter
6. On underside of case: SWITCH for Manual (Potentiometer) or 0-10 volt control & Follower control.
7. Terminal Strip for :
 - 1) D.C. Output for brake or clutch coil (+ , -)
 - 2) Ground (\perp)
 - 3) 0-10 Volt Input Signal (0-10v, COM.)
 - 4) Follower Arm Potentiometer
8. A.C. input, A.C. power On/Off switch, input fuse

SPECIFICATIONS

Input : 120 Volts A.C. 50 / 60 Hz., fused at 1 ampere

Output: PS-12-MC, 0-12 volts D.C., 1.25 amps, 15 watts

PS-24-MC, 0-24 volts D.C., 0.75 amps, 22 watts

Fused at 2 amperes (internal)

0-10 Volt Input Resistance: 2000 ohms

POWER SUPPLY - PS-MC

INSTRUCTIONS - MANUAL (Potentiometer) CONTROL

MODELS: All enclosed power supplies

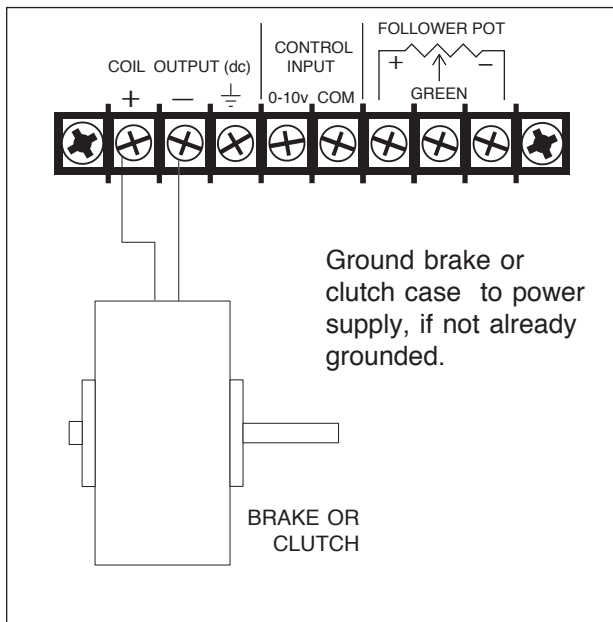

ADJUSTMENTS - When Using Manual (Potentiometer) Control:

% RATED CURRENT POTENTIOMETER - To control output current, from 0% to 100%.

SPAN MAX. - Sets the maximum output current. Is a 15 turn potentiometer. Use the miniature plastic screwdriver provided to make adjustments.

SPAN MIN. - Sets the output current to zero when the % RATED CURRENT potentiometer is set to zero. Is a 15 turn potentiometer. Use the miniature plastic screwdriver provided to make adjustments.

INITIAL SET UP - When Using Manual (Potentiometer) Control:

- 1) Determine the 100% rated current of the brake (or clutch) from the data sheet, or estimate it from the formula:
$$100\% \text{ rated current} = (\text{rated voltage}) / (\text{coil resistance, ohms})$$

The rated voltage is listed on the label of the brake or clutch.
- 2) For safety, disconnect the A.C. power.
- 3) Set 'SWITCH' (on underside of case) to position 2, 'FRONT PANEL POTENTIOMETER' position, so the output current is controlled by the % Rated Current Potentiometer.
- 4) Set the SPAN MAX. potentiometer fully counter-clockwise (for minimum output current).
- 5) Connect A.C. power.
- 6) Set the % RATED CURRENT potentiometer to 100% (for maximum output current).
- 7) SPAN MAX. - Turn the SPAN MAX. potentiometer clockwise until output current equals the 100% rated current of the brake (or clutch).
- 8) SPAN MIN. - Set the % RATED CURRENT potentiometer to 10%. Adjust the SPAN MIN. potentiometer until the output current is 10% of rated current.
- 9) Recheck Steps 6 - 8.

POWER SUPPLY - PS-MC

INSTRUCTIONS - 0-10 VOLT CONTROL

MODELS: All enclosed power supplies

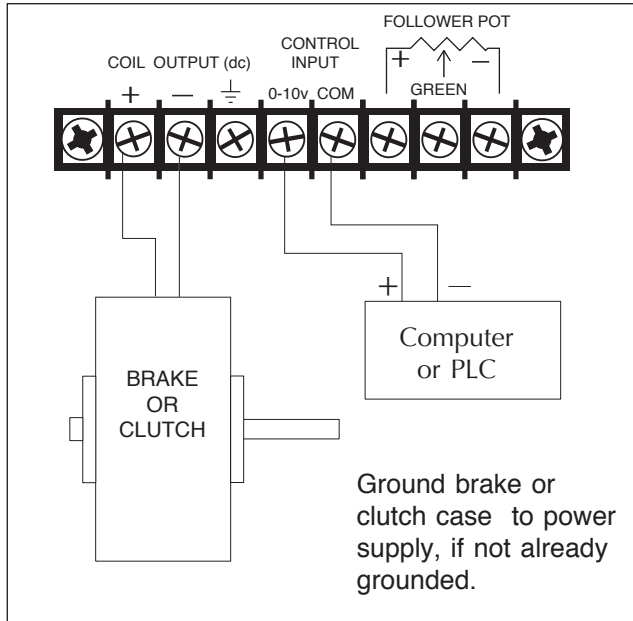

ADJUSTMENTS - When Using 0-10 Volt Control:

0-10 VOLT INPUT SIGNAL - Output current is proportional to the user's 0-10 volt input signal. At 0 volts, output current is 0. At 10 volts, output current is maximum.

SPAN MAX. - This 15 turn potentiometer sets the maximum output current level.

SPAN MIN. - This 15 potentiometer sets the output current to zero when the 0-10 volt signal is zero volts.

INITIAL SET UP - When Using 0-10 Volt Control:

- 1) Determine the 100% rated current of the brake (or clutch) from the data sheet, or estimate it from the formula:
$$100\% \text{ rated current} = (\text{rated voltage}) / (\text{coil resistance, ohms})$$

The rated voltage is listed on the label of the brake (or clutch).
- 2) For safety, disconnect the A.C. power.
- 3) Set 'SWITCH' (on underside of case) to position 1, '0-10v CONTROL' so the output current is controlled by the 0-10 volt D.C. input signal.
- 4) Set the SPAN MAX. potentiometer fully counter-clockwise, approximately 15 turns, or until it clicks (for minimum output current).
- 5) Connect A.C. power.
- 6) Set your 0-10 volt signal to 10 volts. (for maximum output current).
- 7) SPAN MAX. ADJ. - Using the miniature plastic screwdriver, turn the SPAN MAX. potentiometer clockwise until the output current equals the 100% rated current of the brake (or clutch).
- 8) SPAN MIN. - Set your 0-10 volt signal to 1 volt. Adjust the SPAN MIN. potentiometer until output current is 10% of rated current.
- 9) Recheck Steps 6 - 8.

POWER SUPPLY PS-MC

INSTRUCTIONS - HOW TO REPEATEDLY CYCLE BETWEEN 0 AMPERES & ANY CURRENT LEVEL

DO NOT power up & power down the AC input. DO NOT interrupt the DC output wires.

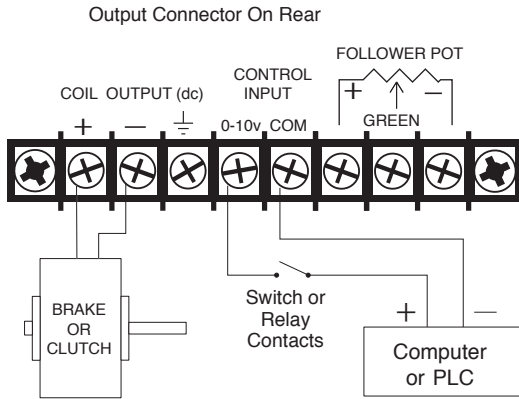

When using 0 - 10 VOLT CONTROL:

If the signal voltage cannot be brought to 0, then use a switch or relay to interrupt the 10 volt signal.

When the wire is connected, output current is controlled by the 0-10v signal.

With the wire disconnected, power supply output current is zero.

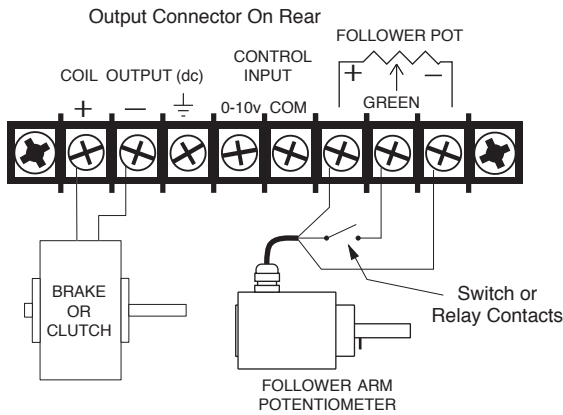

When using a FOLLOWER ARM POTENTIOMETER:

Swing the follower arm into the inactive region. If this is not possible, then disconnect the wiper using a switch or relay.

When the wire is connected, output current is controlled by the follower arm potentiometer.

With the wire disconnected, power supply output current is zero.

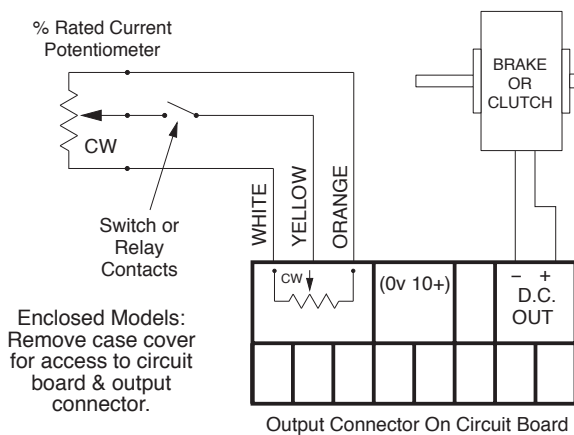

When using MANUAL (Potentiometer) control:

Use a switch or relay to interrupt the yellow wire to the % Rated Current Potentiometer (the wire to the wiper).

When the wire is connected, output current is controlled by the % Rated Current Potentiometer.

With the wire disconnected, power supply output current is zero.