

Ultrasonic Sensor U-B

MAINTAIN CONSTANT TENSION - The ultrasonic sensor is used to maintain constant tension when using a brake for producing unwind (payout) tension, or when using a clutch for rewind tension.

The sensor measures the diameter of the roll & sends a 0-10 VDC signal to the Placid power supply. Torque is automatically varied as roll size changes, to keep tension constant. The sensor measures distances by sending an ultrasonic pulse of sound, and then measuring the time for the return echo pulse.

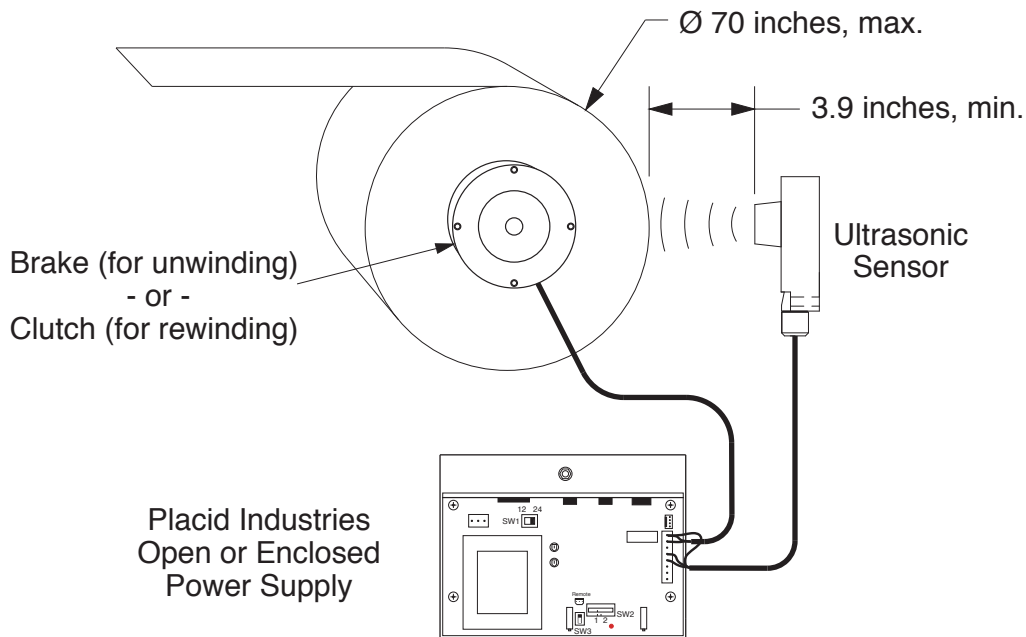
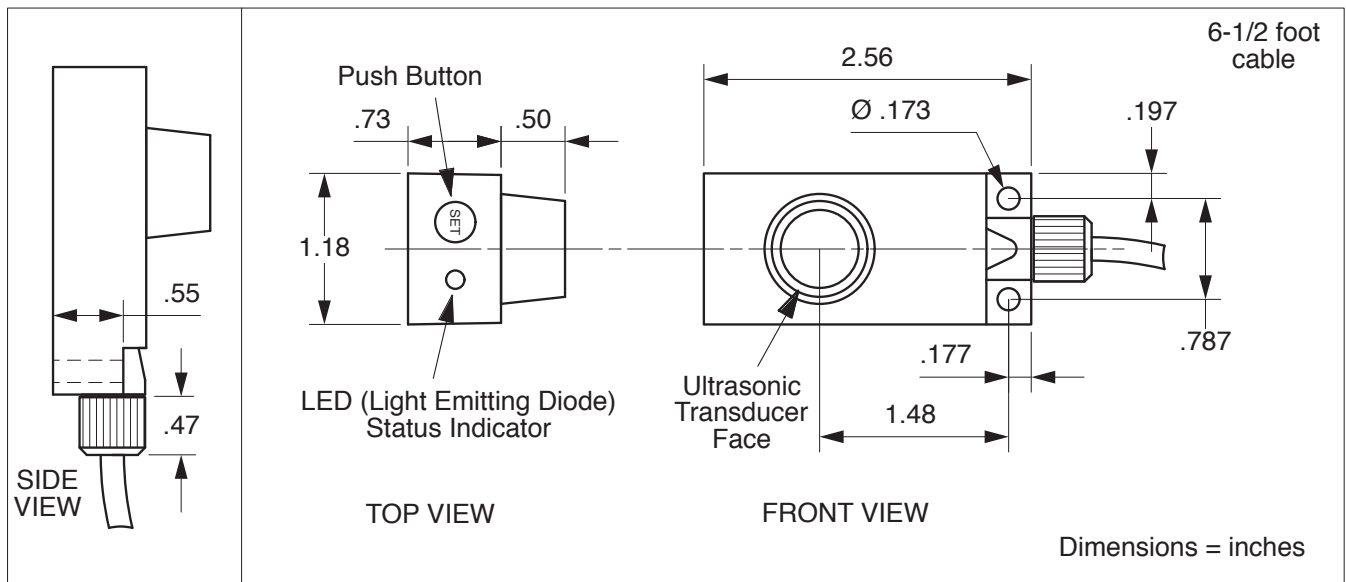

Placid Industries, Inc.

139 Mill Pond Drive, Lake Placid, NY 12946 USA

www.placidindustries.com

Phone 518 523-2422

Fax 518 523-2746

U-B:P1

1/1/05

Ultrasonic Sensor U-B

The ultrasonic sensor measures the distance to the roll with ultrasonic sound. The sensor sends out a pulse of ultrasonic sound, and then measures the time for the echo pulse to return, to determine distance.

MOUNTING SENSOR

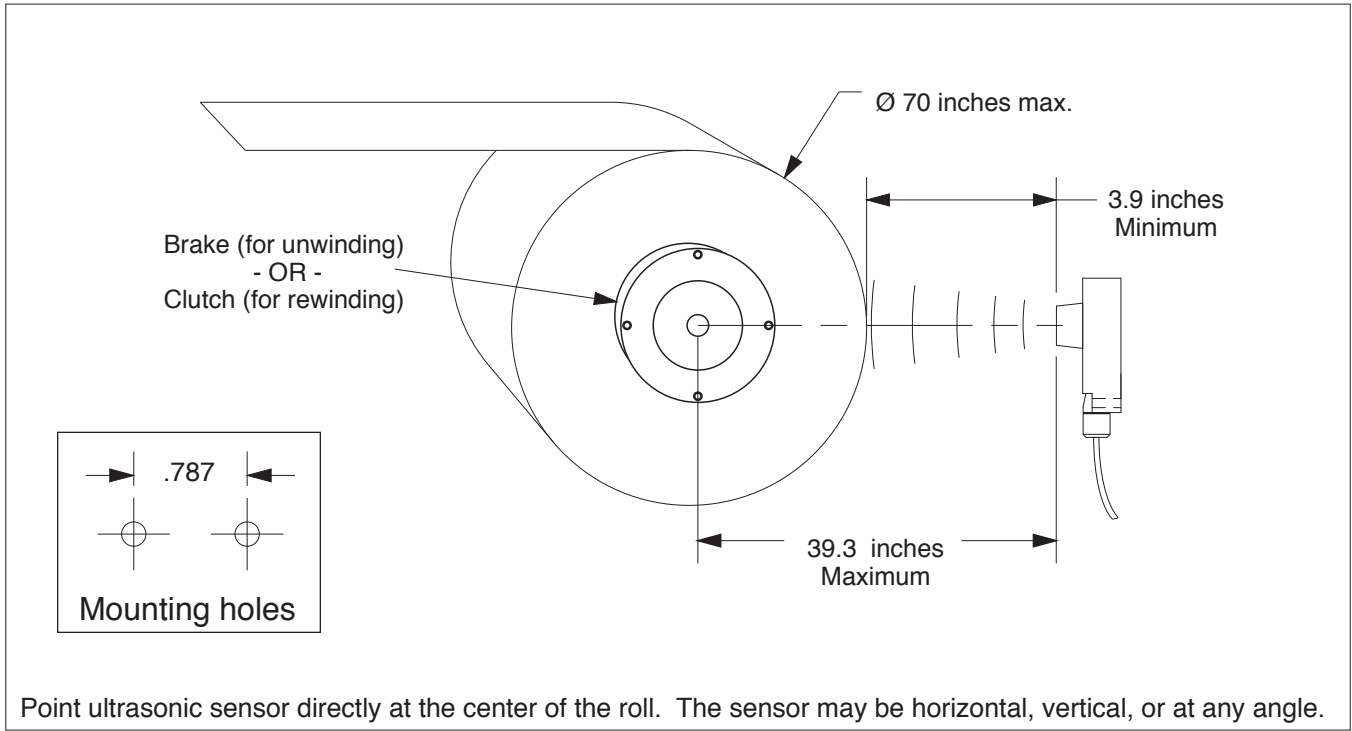

ULTRASONIC BEAM SIZE

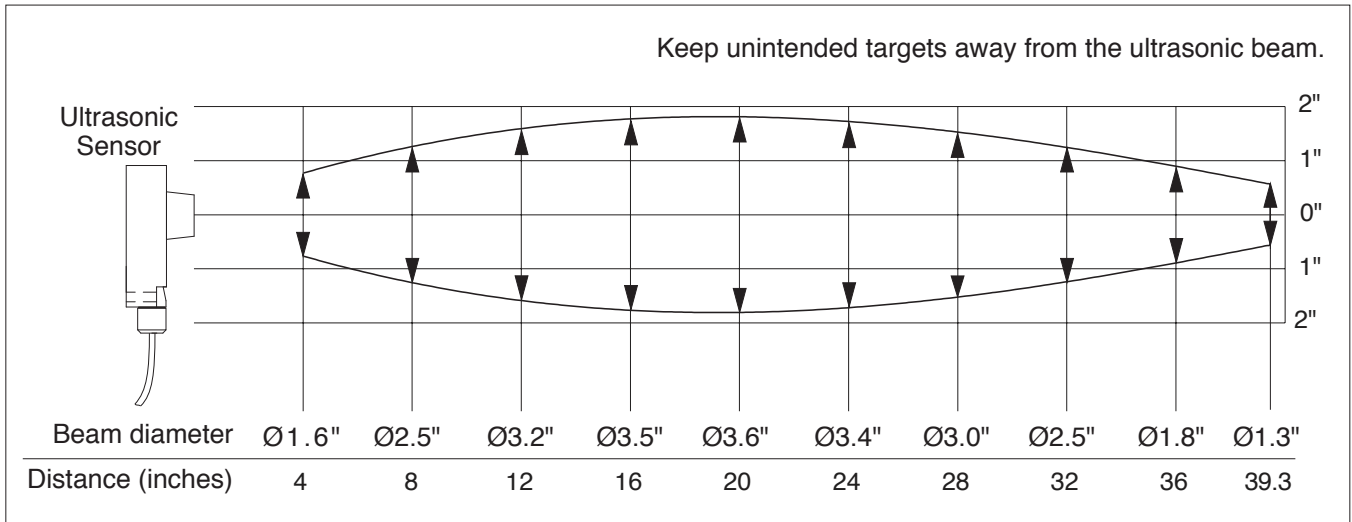

Ultrasonic Sensor U-B

WIRING CONNECTIONS

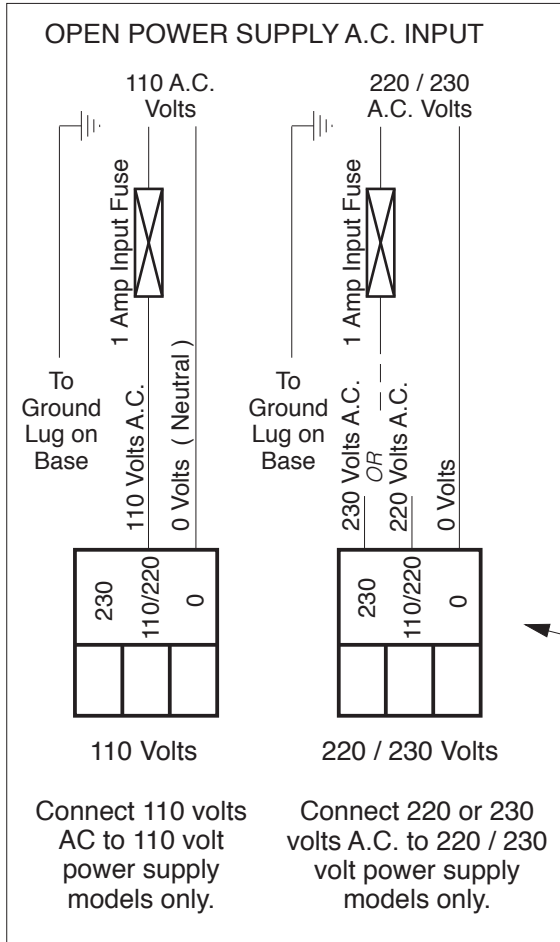

Unplug the top portion of input & output connector to attach wires.

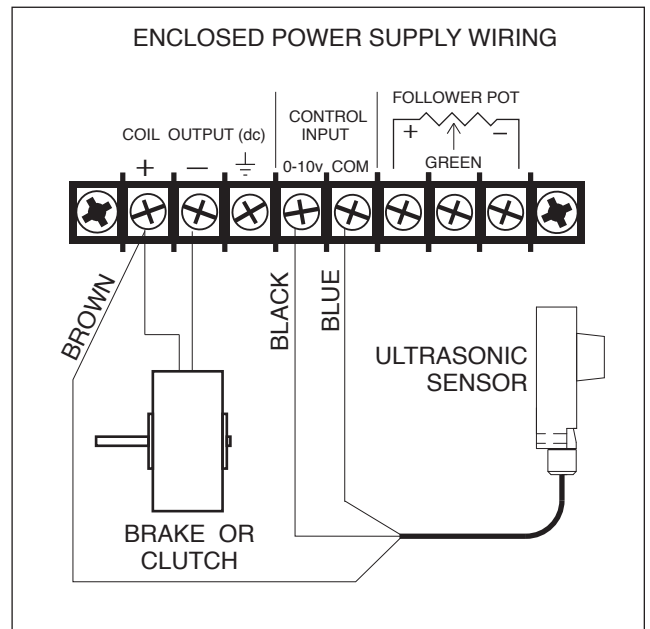
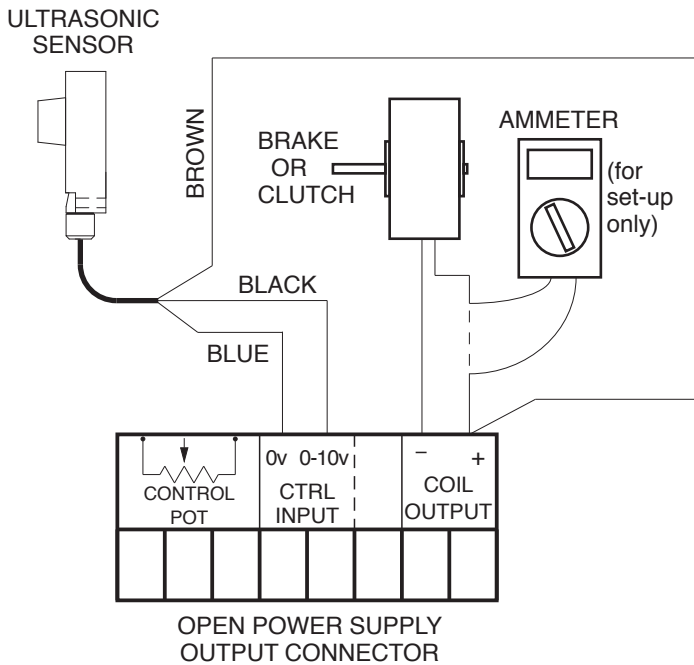
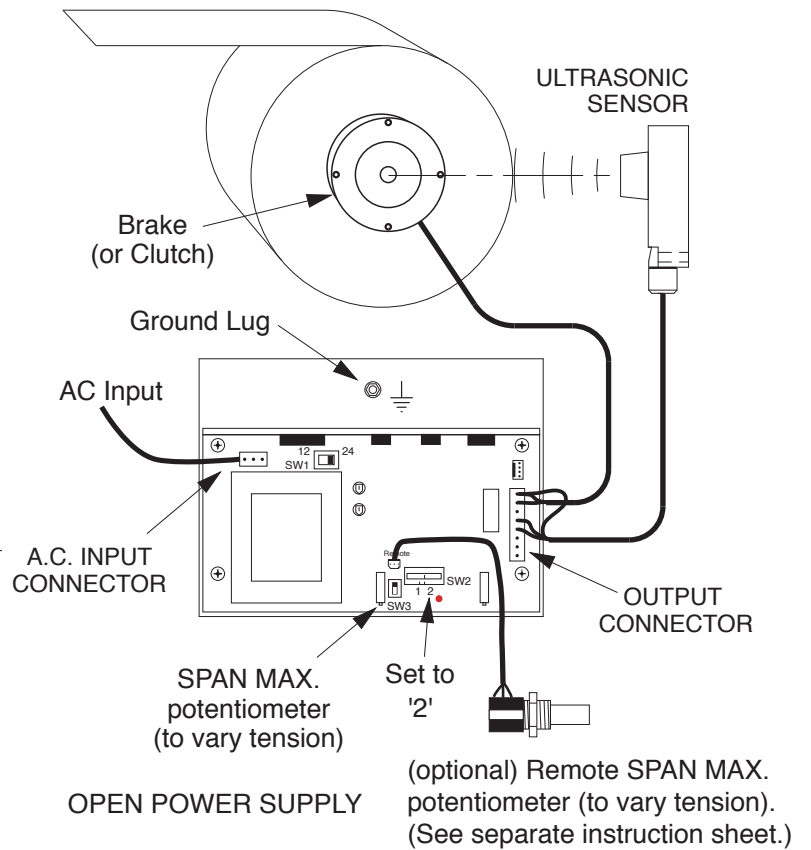

Placid Industries, Inc.

139 Mill Pond Drive, Lake Placid, NY 12946 USA

www.placidindustries.com

Phone 518 523-2422

Fax 518 523-2746

U-B:P3

10/7/04

Ultrasonic Sensor U-B

WIRING A REMOTE TENSION ADJUSTMENT POTENTIOMETER TO AN OPEN POWER SUPPLY

The web *tension* is varied by adjusting the on-circuit-board Span Max. potentiometer or by a remotely mounted Span Max. potentiometer on the operator's panel.

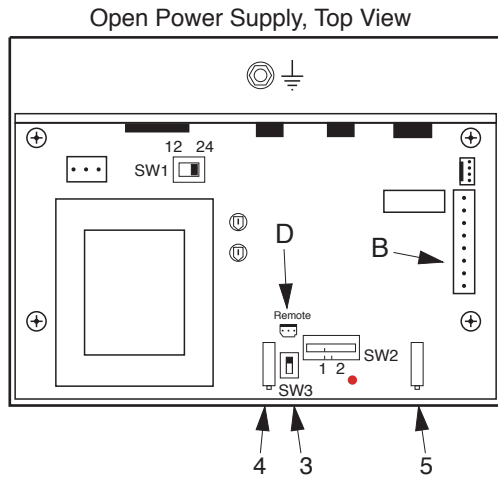

B. OUTPUT CONNECTOR

D. PLUG, 3 prong, - for a remote Span Max. Potentiometer, (for conveniently making tension adjustments when using the Follower Arm Potentiometer or Ultrasonic Sensor)

3. SWITCH SW3 - to select either the on-circuit-board Span Max. pot. or remote Span Max. potentiometer
4. SPAN MAX. potentiometer - (for tension adjustments)
5. SPAN MIN. potentiometer - When using an ultrasonic sensor, set fully counter-clockwise, (10+ turns, until it clicks)

WIRING THE POTENTIOMETER FOR REMOTE TENSION ADJUSTMENTS

The web tension is varied by adjusting the on-circuit-board Span Max. Pot or by a remotely mounted Span Max pot on the operator's panel. Slide switch SW3 towards the 'Remote' plug, to select the remote pot.

The same 500 ohm potentiometer that is used as the % Rated Current Pot in Manual Mode, can be used as the remote Span Max. pot.

Disconnect the % Rated Current Pot from the Output Connector. Then connect the 3 wires from the pot to the 3 contact receptacle, as shown below. Plug the receptacle into 'D', marked 'Remote' on the power supply circuit board.

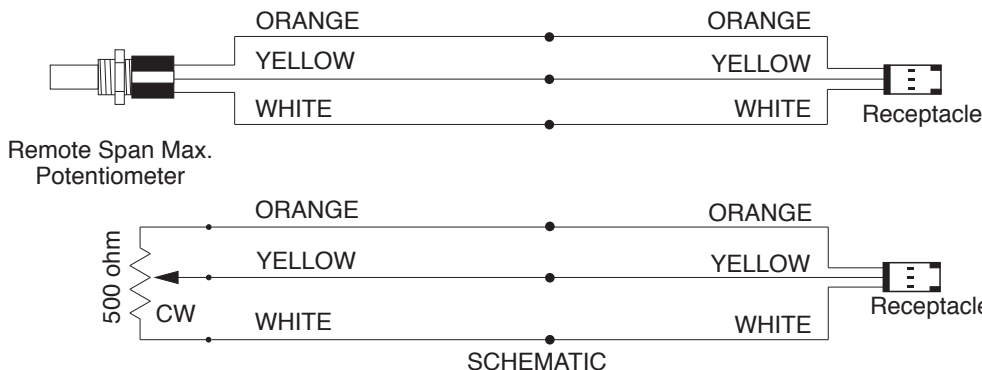

Connect the 3 contact receptacle, to 'D', (marked 'Remote') on power supply circuit board.



Ultrasonic Sensor U-B

PROGRAMMING

The ultrasonic sensor is programmed by pressing the 'SET' button, while viewing the LED Status Indicator'.

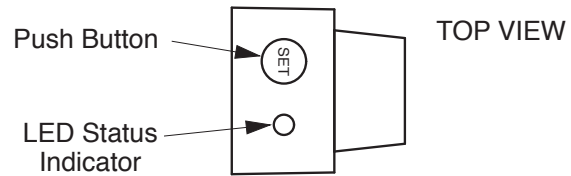

1) Set the ROLL CENTER

Remove the roll, and place an temporary target (a piece of cardboard works well), at the roll centerline, (or about 10% farther away from the sensor, to compensate for the non-linear torque curve of the brake or clutch).

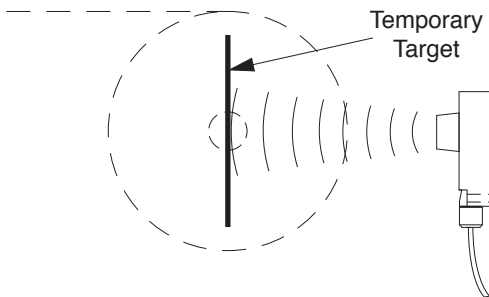

Unlock sensor

Turn off the power supply for 5 seconds, then turn on again. *Note: If the SET button is not pressed within 5 minutes, the sensor needs unlocking again.*

Prepare sensor for programming distances:

Press and hold the 'SET' button for more than 2 seconds but less than 4 seconds, (until the 'LED Status Indicator' flashes alternately yellow and orange). Release the button, and the 'LED Status Indicator' flashes orange.

Set the Roll Center:

With the temporary target in place, momentarily press the 'SET' button. Then the LED flashes yellow.

2) Set the FULL ROLL SIZE

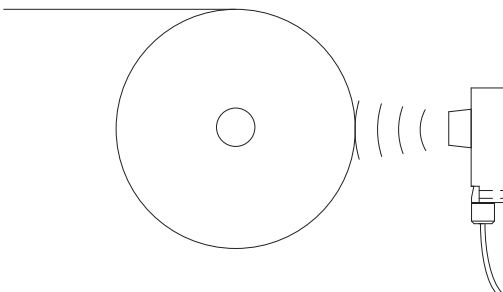

Mount the largest size roll to be used. For convenience, a temporary target may be used instead (a piece of cardboard works well). Position the temporary target at the full roll diameter, or a little closer to the sensor, just in case some rolls are larger.

Note: The sensor must be at least 3.9" from the roll.

Momentarily press the 'SET' button. For 1 second, both the yellow and orange LED are on, then, just the yellow.

If difficulty occurs, or the sensor doesn't respond as expected, turn off the power supply for 5 seconds, and start over.



Ultrasonic Sensor U-B

After set-up and programming, the 'LED Status Indicator' will be continuously glowing yellow, indicating a target is within range.

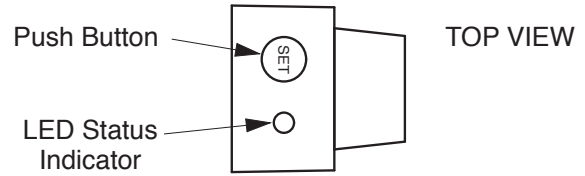

COMMON PROBLEMS

No audible 'buzzing' sounds from sensor

The power is not on, or is connected with reverse polarity. When power is correctly applied, the sensor emits an audible, low volume buzzing sound.

LED Status Indicator - Dark

The power is not on, or is connected with reverse polarity. -or- The target is too close to the sensor, or the target is too far (either out of the programmed range, or out of the maximum possible range).

LED Status Indicator - Doesn't respond when pressing the SET button

The sensor is locked (to prevent accidental reprogramming). The sensor automatically locks if the SET button is not pressed within 5 minutes. To unlock sensor - Turn off the power supply for 5 seconds, and turn on again.

LED Status Indicator - Flashing

The sensor is in the programming mode. Recheck programming procedure.

LED Status Indicator - Glowing Orange

The sensor detects an object, but is too close.

Output increases as roll diameter decreases

Set the roll center first. Then set the full roll size.

SPECIFICATIONS

Power Input	15-30 VDC @ 35 ma. max.
Range	3.9 - 39.3 inches (100-1000 mm)
Output	0 to 10 volts D.C. 20 mAmps max. Push-Button adjustable end points.
Resolution	0.012 inches (<0.3 mm)
Repeatability	0.02 inches (<0.5 mm)
Temperature	14 to 140 °F (-10 to +60 °C)
Protection class	IP67
Housing material	Polyester

TRANSDUCER

Type	Ultrasonic
Beam Shape	Conical
Beam Angle	10 degrees total

PRECAUTIONS

- Keep sensor away from sources of ultrasonic noise, such as pressurized air nozzles (air guns).
- Keep unintended targets from the sensor's field of view. Keep the beam pattern in mind.

TEMPERATURE EFFECTS

At room temperature, a change of 10[∞] will result in approximately 1% change (due to changes in the speed of sound).



Placid Industries, Inc.

139 Mill Pond Drive, Lake Placid, NY 12946 USA

www.placidindustries.com

Phone 518 523-2422

Fax 518 523-2746

U-B:P6

6/11/04

Ultrasonic Sensor U-B

POWER SUPPLY ADJUSTMENTS

Open
Power Supply

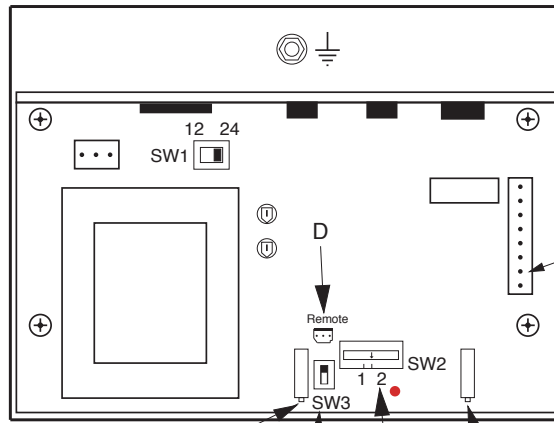

Output
Connector

SPAN MIN. POTENTIOMETER -
Important - Set fully counter-clockwise
(15 turns total or until it clicks).

Set switch SW2
to Position 2

TENSION ADJUSTMENT POTENTIOMETER
Web tension is varied by either:
This circuit board mounted SPAN MAX.
potentiometer, - or -
a REMOTE SPAN MAX. potentiometer
(which connects at PLUG 'D'.)

SWITCH SW3 TO SELECT -
ON-CIRCUIT BOARD SPAN MAX POTENTIOMETER for tension adjustments:
Set SWITCH SW3 towards the edge of the circuit board.
- OR -
REMOTE SPAN MAX POTENTIOMETER for tension adjustments: Set SWITCH
SW3 towards the middle of the circuit board .
Note: The Remote Span Max. potentiometer is plugged into 'D'.

Note: Percent Rated Current
Potentiometer has no effect.

Enclosed
Power Supply

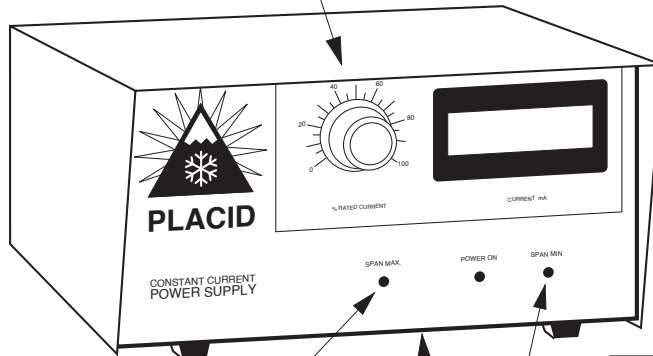

SPAN MIN. POTENTIOMETER -
Important - Set fully counter-clockwise
(15 turns total or until it clicks).

**TENSION ADJUSTMENT
POTENTIOMETER**
Web tension is varied by the circuit board
mounted SPAN MAX. potentiometer.

SWITCH (on underside of case)
Set to POSITION 1:
0-10v CONTROL OR
REMOTE FOLLOWER



Placid Industries, Inc.

139 Mill Pond Drive, Lake Placid, NY 12946 USA

www.placidindustries.com

Phone 518 523-2422

Fax 518 523-2746

U-B:P7

1/1/05