

POWER SUPPLY - PS

110 Volts AC Models: PS-12, PS-24
 220 Volts AC Models: PS-12-2, PS-24-2

LOCATION OF COMPONENTS

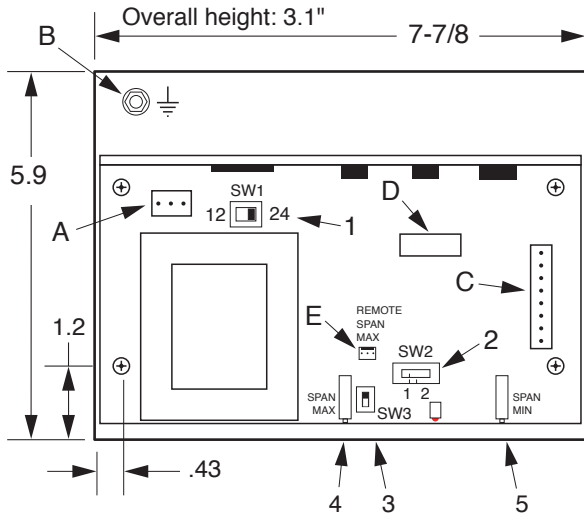

- A. A.C. INPUT CONNECTOR - A.C. input
- B. GROUND LUG
- C. OUTPUT CONNECTOR - DC out, 0-10 input, % Rated Current Potentiometer, or Follower Arm Potentiometer or Ultrasonic Sensor.
- D. OUTPUT FUSE - 2 amp, 5 x 20 mm.
- E. PLUG, 3 prong, for a remote Span Max. pot, (for tension adjustments when using the Follower Arm Potentiometer or Ultrasonic Sensor.)

- 1. SWITCH SW1 - 12 or 24 volt output selector switch. (Slide switch towards 12 when using a 12 volt brake or clutch. Slide switch towards 24 when using a 24 volt brake or clutch.)
- 2. SWITCH SW2 - to select the method of controlling the output current: Position (1) - Potentiometer, or Position (2) - The 0-10 volt D.C. input signal.
- 3. SWITCH SW3 - to select a remote Span Max. potentiometer (for tension adjustments when using the Follower Arm Potentiometer or Ultrasonic Sensor.)
- 4. SPAN MAX. potentiometer
- 5. SPAN MIN. potentiometer.

4 threaded mounting studs: (on underside of sheet metal base) 2.92" x 6.96" #6-32 threads

MOUNTING HOLES

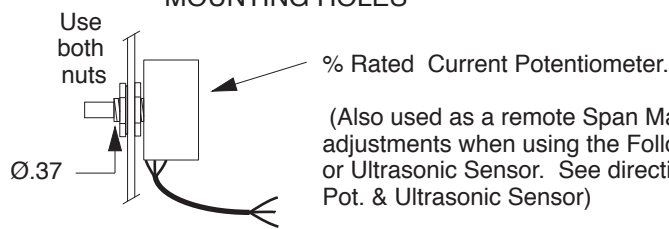
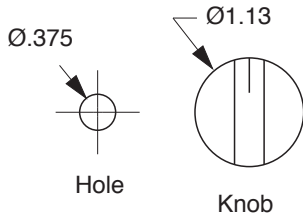

(Also used as a remote Span Max. pot for tension adjustments when using the Follower Arm Potentiometer or Ultrasonic Sensor. See directions with Follower Arm Pot. & Ultrasonic Sensor)

A.C. INPUT, 110 VOLTS -- Models PS-12 & PS-24

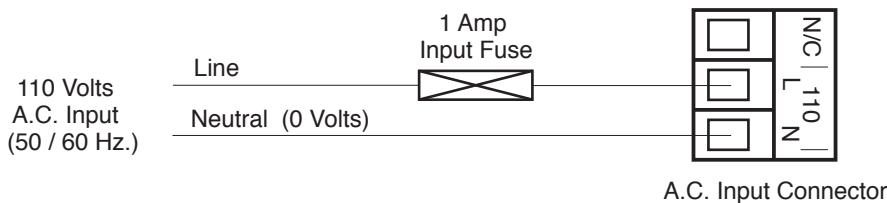

Unplug the top portion of the Input Connector to attach wires.

A.C. INPUT, 220 / 230 VOLTS -- Models PS-12-2 & PS-24-2

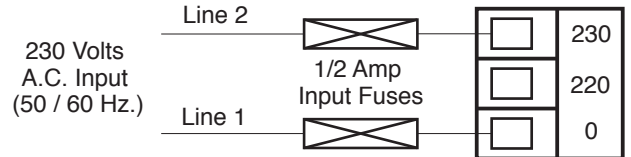
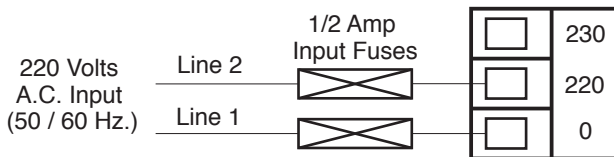

Unplug the top portion of the Input Connector to attach wires.

For most foreign installations: Omit the fuse on the 0 input when Line1 is grounded at the service entrance.



Placid Industries, Inc.

139 Mill Pond Drive, Lake Placid, NY 12946 USA

www.placidindustries.com

Phone 518 523-2422

Fax 518 523-2746

Starting Serial # 07-xxx 7/13

P1/4

POWER SUPPLY - PS

SPECIFICATIONS

Output Current: D.C., constant current type

12 volt: 1.25 amps

24 volt: 0.75 amps

Output Fuse: 2 amperes, located on circuit board.

0-10 Volt Input Resistance: 2000 ohms

120 Volts A.C. input

PS-12 : 0-12 VDC output

PS-24 : 0-24 VDC output

220 Volts A.C. input

PS-12-2 : 0-12 VDC output

PS-24-2 : 0-24 VDC output

INSTRUCTIONS - MANUAL (Potentiometer) CONTROL

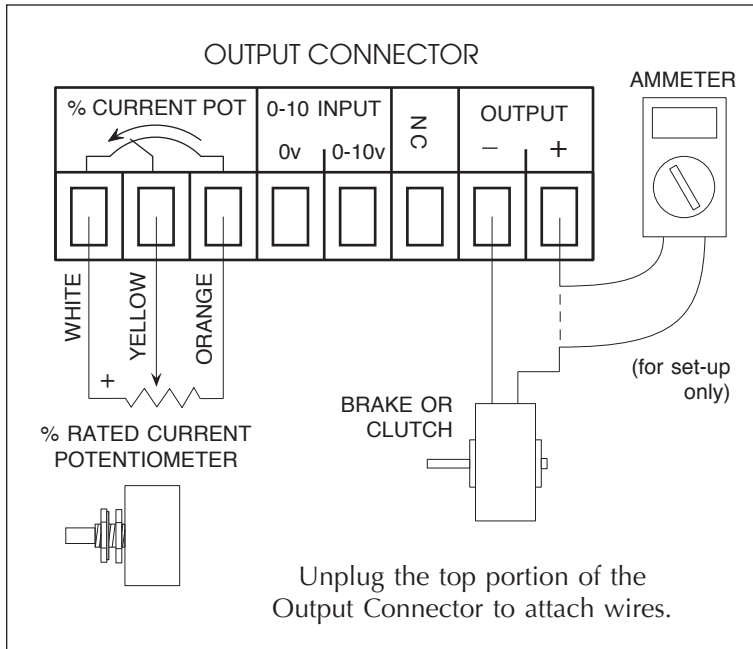

ADJUSTMENTS - When Using Manual (Potentiometer) Control:

% RATED CURRENT POTENTIOMETER - The remotely mountable potentiometer controls the desired output current, and is adjustable from 0% to 100%. This is used to control output torque.

SPAN MAX. - Sets the maximum output current. The 10 turn potentiometer is mounted on the circuit board. Use the miniature plastic screwdriver provided to make adjustments.

SPAN MIN. - Sets the output current to zero when the % RATED CURRENT potentiometer is set to zero. The 10 turn potentiometer is mounted on the circuit board. Use the miniature plastic screwdriver provided to make adjustments.

INITIAL SET UP - When Using Manual (Potentiometer) Control:

- 1) Determine the 100% rated current of the brake (or clutch) from the data sheet, or calculate it from the formula:
$$100\% \text{ rated current} = (\text{rated voltage}) / (\text{coil resistance, ohms})$$

The rated voltage is listed on the label of the brake or clutch.
- 2) For safety, disconnect the A.C. power.
- 3) Set SWITCH SW2 to position 1, so the output current is controlled by the % Rated Current Potentiometer. Set SWITCH SW3 towards the edge of the circuit board to select the on-board Span Max. Potentiometer.
- 4) Set the SPAN MAX. potentiometer fully counter-clockwise (for minimum output current).
- 5) Temporarily connect a (customer supplied) ammeter in series with the brake (or clutch). (See wiring diagram.)
- 6) Connect A.C. power.
- 7) Set the % RATED CURRENT potentiometer to 100% (for maximum output current).
- 8) SPAN MAX. - Turn the SPAN MAX. potentiometer clockwise until your ammeter displays the current level corresponding to the 100% rated current of the brake (or clutch).
- 9) SPAN MIN. - Set the % RATED CURRENT potentiometer to 10%. Adjust the SPAN MIN. potentiometer until your ammeter shows the power supply output current is at 10% of rated current.
- 10) Recheck Steps 7 & 8.
- 11) Disconnect your (customer supplied) ammeter. Reconnect the brake (or clutch) to Output Connector.



Placid Industries, Inc.

139 Mill Pond Drive, Lake Placid, NY 12946 USA

www.placidindustries.com

Phone 518 523-2422

Fax 518 523-2746

Starting Serial # 07-1 1/07

P2/4

POWER SUPPLY - PS

INSTRUCTIONS - 0-10 VOLT CONTROL

MODELS	120 Volts A.C. input	220 Volts A.C. input
	PS-12 : 0-12 VDC output	PS-12-2 : 0-12 VDC output
	PS-24 : 0-24 VDC output	PS-24-2 : 0-24 VDC output

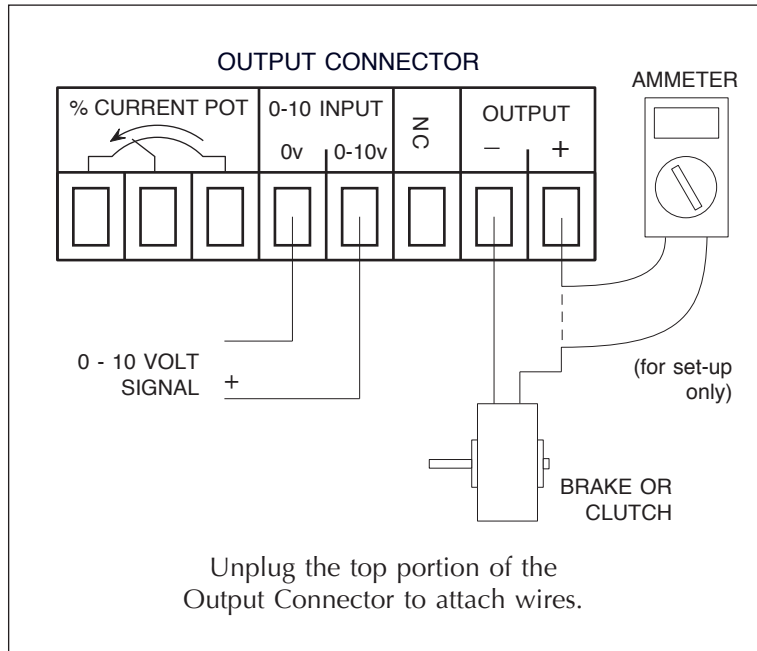

ADJUSTMENTS - When Using 0-10 Volt Control:

0-10 VOLT INPUT SIGNAL - Output current is proportional to the user's 0-10 volt input signal. At 0 volts, output current is 0. At 10 volts, output current is maximum.

SPAN MAX. - This potentiometer sets the maximum output current level, when the 0-10 volt signal is 10 volts.

SPAN MIN. - This potentiometer sets the output current to zero when the 0-10 volt signal is zero volts.

INITIAL SET UP - When Using 0-10 Volt Control:

- 1) Determine the 100% rated current of the brake (or clutch) from the data sheet, or calculate it from the formula:
$$100\% \text{ rated current} = (\text{rated voltage}) / (\text{coil resistance, ohms})$$

The rated voltage is listed on the label of the brake (or clutch).
- 2) For safety, disconnect the A.C. power.
- 3) Set SWITCH SW2 to position 2 so the output current is controlled by the 0-10 volt D.C. input signal.
Set SWITCH SW3 towards the edge of the circuit board to select the on-board Span Max. Potentiometer.
- 4) Set the SPAN MAX. potentiometer fully counter-clockwise (for minimum output current).
- 5) Temporarily connect a (customer supplied) ammeter in series with the brake (or clutch). (See wiring diagram.)
- 6) Connect A.C. power.
- 7) Set your 0-10 volt signal to 10 volts. (for maximum output current).
- 8) SPAN MAX. ADJ. - Turn the SPAN MAX. potentiometer clockwise until the output current equals the 100% rated current of the brake (or clutch).
- 9) SPAN MIN. - Set your 0-10 volt signal to 1 volt. Adjust the SPAN MIN. potentiometer until your ammeter indicates the power supply output current is 10% of rated current.
- 10) Recheck Steps 7 & 8.
- 11) Disconnect your (customer supplied) ammeter. Reconnect the brake (or clutch) to Output Connector.



POWER SUPPLY - PS

Cycling Between 0 Amps & Any Current Level When Using Manual (Potentiometer) Control

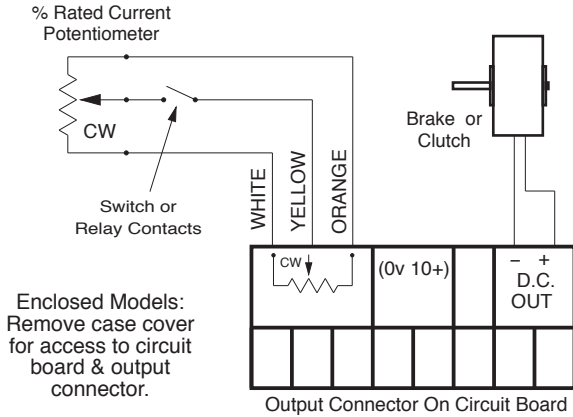

DO NOT power up & power down the AC input repeatedly.
DO NOT- interrupt & connect the D.C. OUT wires repeatedly.

Correct method, when using MANUAL (Potentiometer) control:

Use a switch or relay to interrupt the yellow wire to the % Rated Current Potentiometer (the wire to the wiper).

When the wire is connected, output current is controlled by the % Rated Current Potentiometer.
When the relay interrupts (disconnects) the wiper, power supply output current is zero.

Cycling Between 0 Amps & Any Current Level When Using 0 - 10 volt Control

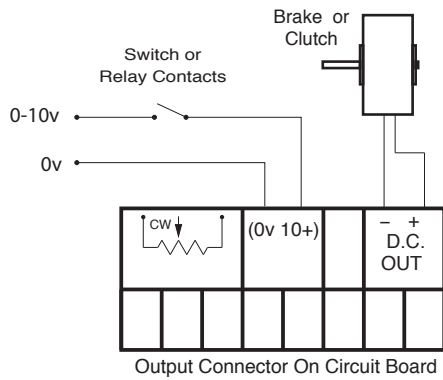

DO NOT power up & power down the AC input repeatedly.
DO NOT- interrupt & connect the D.C. OUT wires repeatedly.

Correct method, when using 0 - 10 volt control:

If the signal voltage cannot be brought to 0, use a switch or relay to interrupt the 10 volt signal.

When the wire is connected, output current is controlled by the 0-10v signal.

When the relay interrupts (disconnects), power supply output current is zero.

Powering Multiple Brakes or Clutches

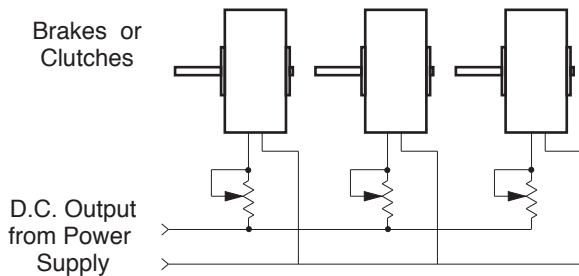

One power supply can power more than one clutch (or brake).
Total output current, 12 volt model=1.25 amps. Total output current, 24 volt model= 0.80 amps.

Note: all clutches (or brakes) will have the same voltage applied, so output torque will be about the same.

For closely matched torque, an adjustable series resistor, of about 15% of the clutch (or brake) coil may be used to adjust for slight torque differences.

Connect 110 volts AC to 110 volt models, only.

Connect 220 volts AC or 230 AC to 220 volt models only. 220V Models: PS-12-2, PS-24-2, PS-12-M2, PS-24-M2



Placid Industries, Inc.

139 Mill Pond Drive, Lake Placid, NY 12946 USA

www.placidindustries.com

Phone 518 523-2422

Fax 518 523-2746

P4/4