

MAGNETIC PARTICLE CLUTCH PHC - 100

THE FINNED BODY ROTATES WITH THE INPUT SHAFT.
 HOLD THE WIRES STATIONARY BY THE 2 SLOTTED TABS.
 THE 35mm BORE IS COUPLED TO THE INPUT SHAFT
 WITH ELECTRICAL EXCITATION.

MAY BE USED AS A BRAKE BY
 HOLDING THE FINNED BODY
 STATIONARY.

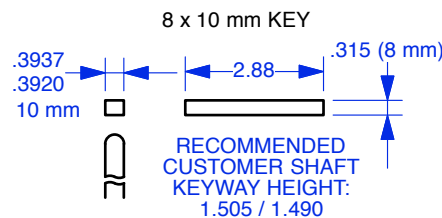
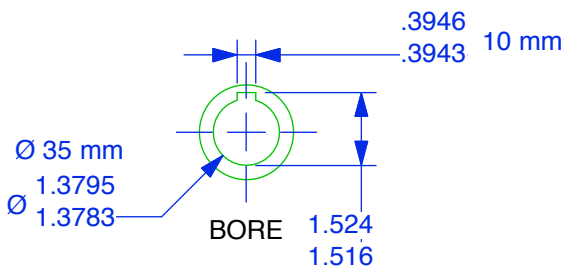
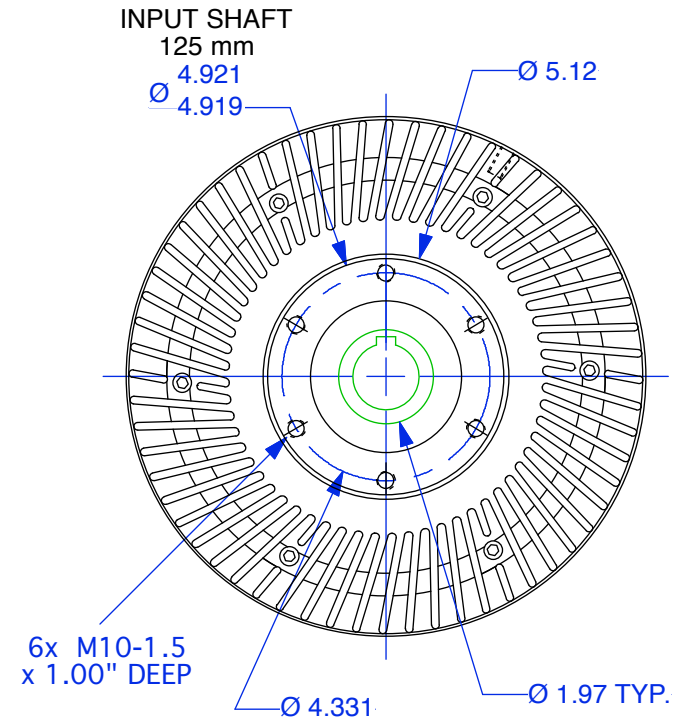
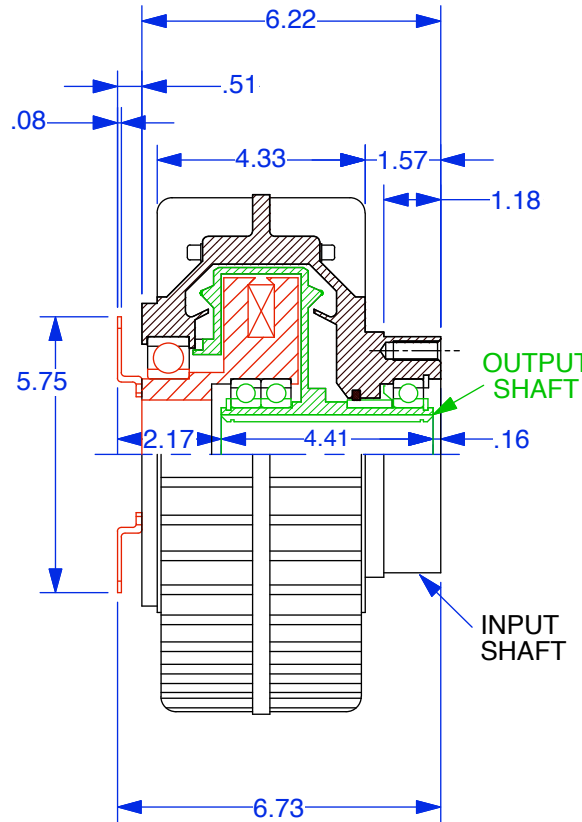
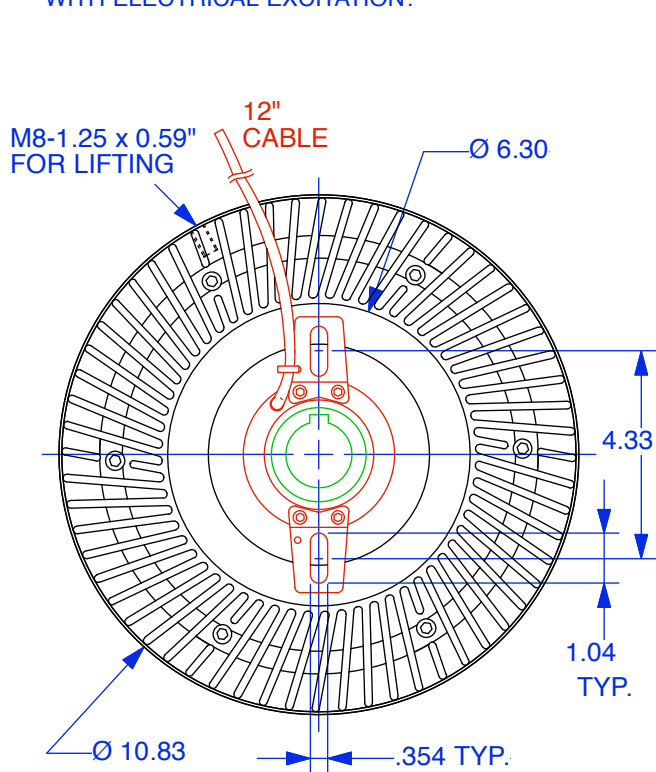

TORQUE RANGE = 1 - 65 LB.-FT.
 RATED VOLTAGE = 24 VDC
 INPUT CURRENT = 2.2 AMPS
 COIL RESISTANCE = 10 OHMS
 MAX. RPM = 1000
 WEIGHT = 46 LBS.

Units : inches
 Scale : 1/4

Drawn 12/1/07
 Changed 3/28/14

Lake Placid, NY USA
 Telephone 518 523-2422
 www.placidindustries.com

