

Mini-Follower Arm Potentiometer FM

MAINTAIN CONSTANT TENSION - The follower arm potentiometer is used to maintain constant tension when using a brake for producing unwind (payout) tension, or when using a clutch for rewind tension.

The arm rides on the roll, measuring the roll diameter. As the roll size decreases, the arm moves downward, rotating the potentiometer shaft. The power supply current automatically decreases, which decreases the brake (or clutch) torque to maintain constant tension.

Use the Mini-Follower for small rolls, up to about 6" dia. Use the standard size Follower Arm Potentiometer for larger rolls.

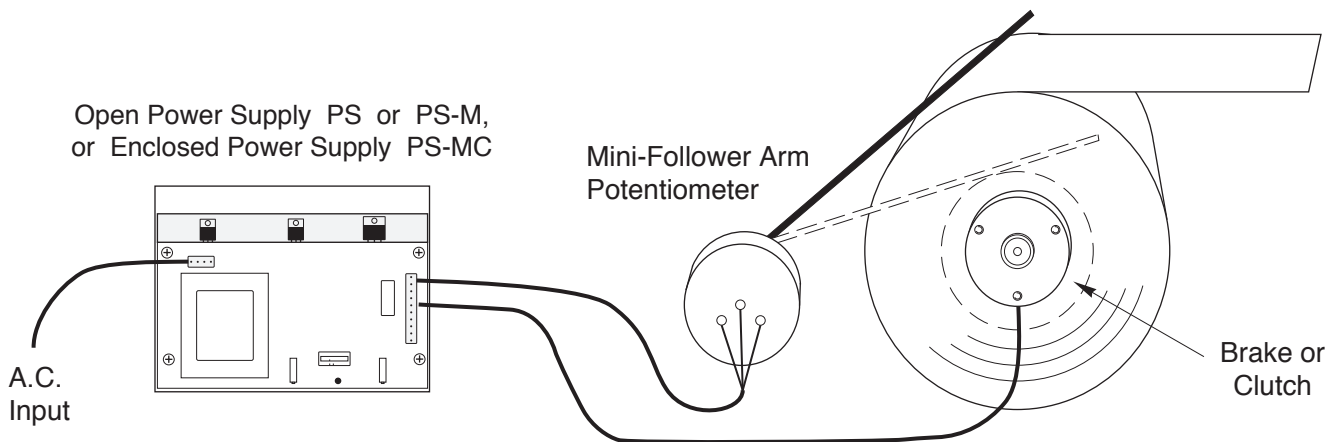
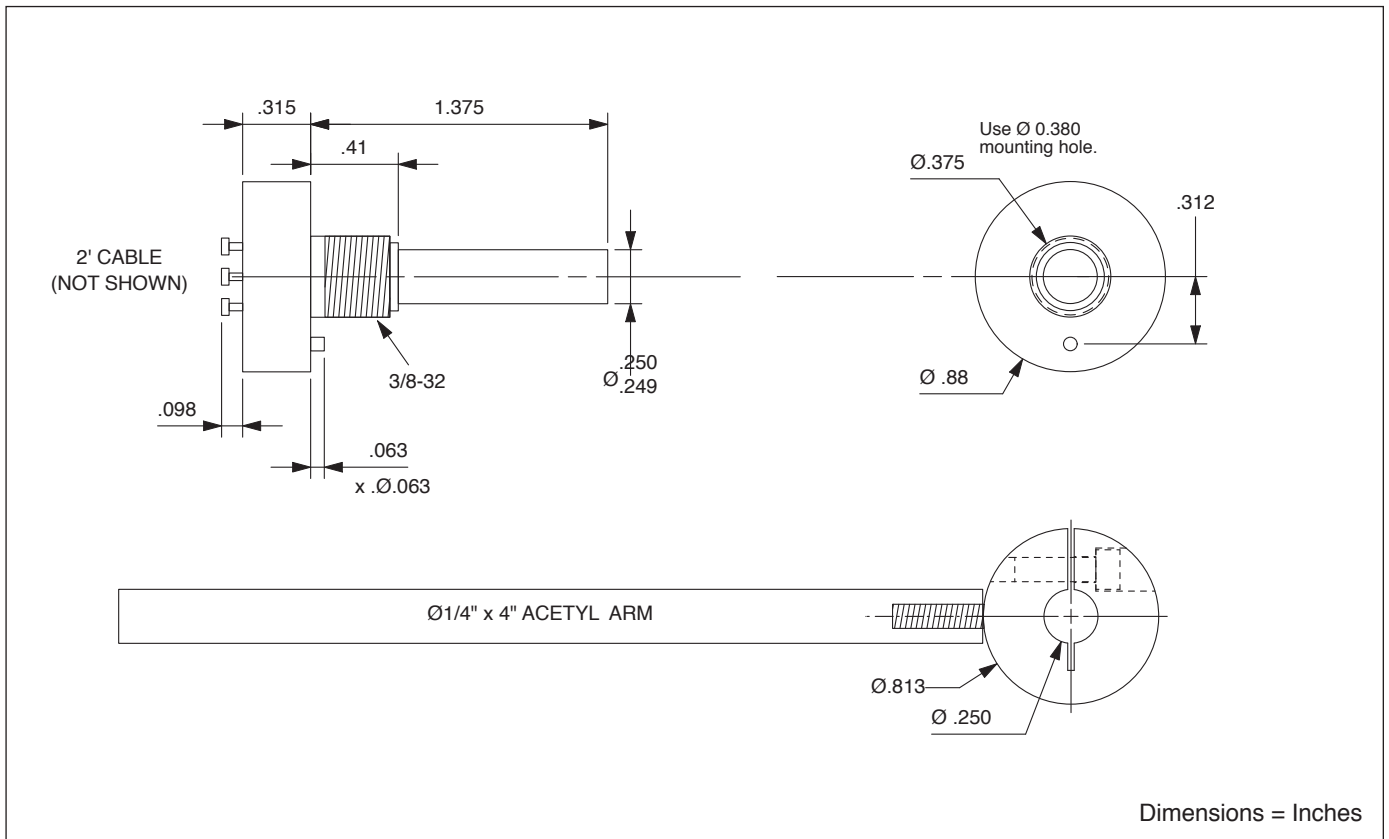

Mini-Follower Arm Potentiometer FM

MOUNTING

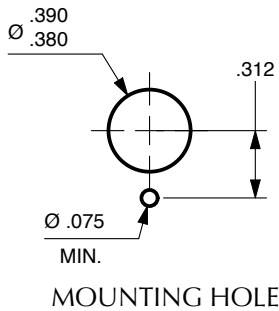

HOLE POSITION - Position the mounting hole close enough to the roll, so the potentiometer arm swings through the largest angle possible (but less than 65°). See drawings with rolls below.

MOUNT POTENTIOMETER - Align anti-rotation pin in potentiometer body with hole. Fasten potentiometer with 3/8" nut & lock washer.

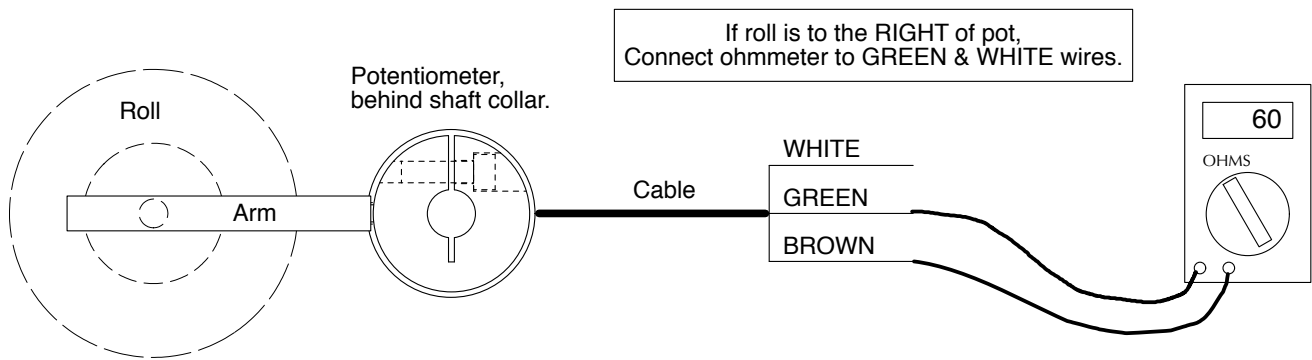

FASTEN SHAFT COLLAR - Temporarily connect a portable ohmmeter to the pot wires as shown. Rotate the potentiometer shaft until resistance is about 60 Ω . Remove your roll. Point the arm towards the center of the roll. Slide the shaft collar / arm assembly onto the potentiometer shaft. Tighten the shaft collar screw, with a 3/32" hex key wrench. Ohmmeter should still be approximately 60 Ohms. If not, loosen the shaft collar screw, and reposition.

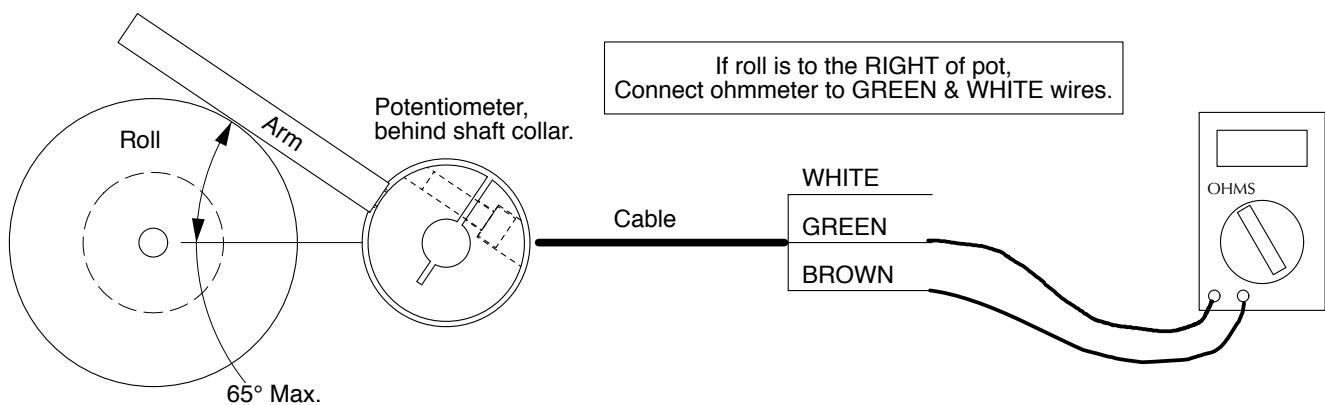

FULL ROLL - Mount the largest roll. Place the arm on the OD of the roll, as shown. Check that the arm travel doesn't exceed 65°. Ohmmeter should not read zero (which would indicate over-travel). Resistance varies from near zero (approximately 60 Ω) to 500 Ω , as the arm travels through 65°.



Mini-Follower Arm Potentiometer FM

WIRING

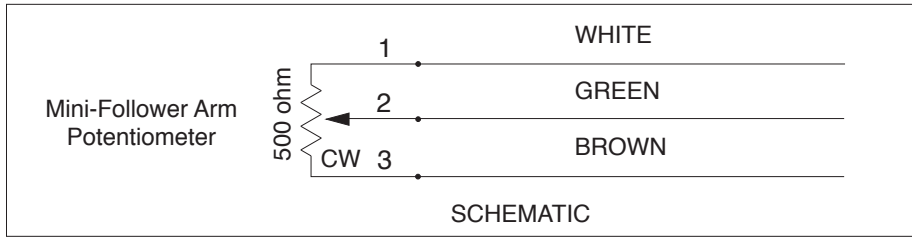

Wiring varies, depending the direction the potentiometer rotates to increase torque.

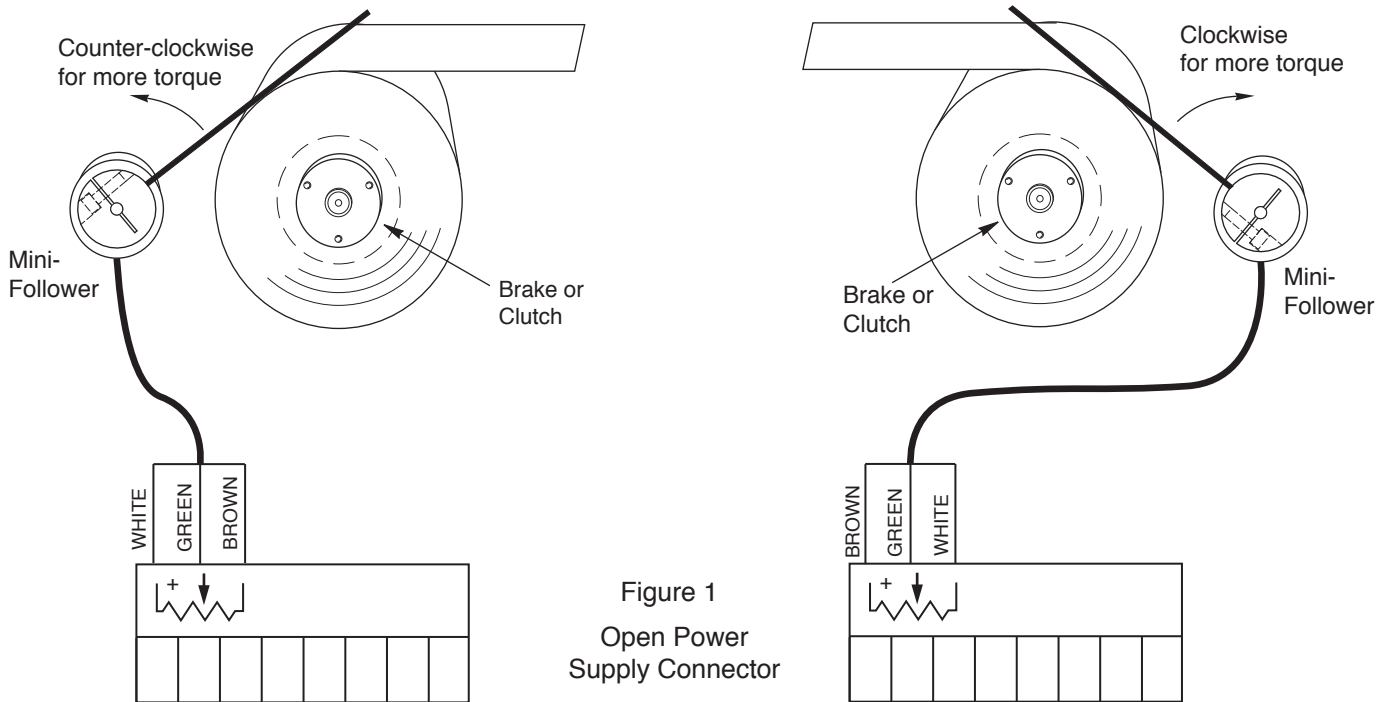

Figure 1
Open Power
Supply Connector

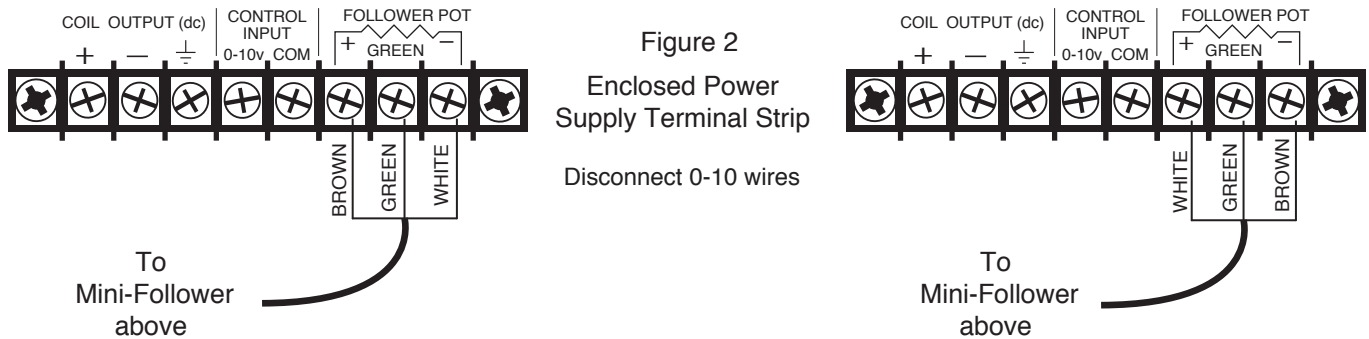

Figure 2
Enclosed Power
Supply Terminal Strip
Disconnect 0-10 wires



Follower Arm Potentiometer & Mini-Follower Arm Potentiometer

SET-UP INSTRUCTIONS FOR THE ENCLOSED POWER SUPPLY, WHEN USING THE FOLLOWER ARM POT.

The Mini-Follower Arm potentiometer connects to the Placid Industries power supply, to provide constant tension for unwinding/rewinding webs.

Resistance - 500 ohms
Electrical Angle - 65 degrees
Mechanical Angle - 360 degrees (No mechanical stops)

WIRING & SWITCH SETTINGS (Enclosed Power Supply)

- 1) For safety, turn off A.C. input power & unplug A.C. input wires.
- 2) Connect the 3 wires from the Follower Arm Potentiometer to the terminal strip on the rear of the power supply, as shown in Figure 2.
- 3) Set the SWITCH (located on the underside of the case) to position 1 (0-10v CONTROL).

INITIAL SET UP

- 1) Determine the desired web tension. Then calculate the torque required to produce the tension when the roll is full.
 $\text{Torque} = \text{Tension} \times \text{Roll radius.}$
- 2) Determine the current required by the brake (or clutch) to produce the tension by consulting the brake (or clutch) torque curve.
- 3) For safety, disconnect the A.C. power to the power supply.
- 4) Set the SPAN MAX. potentiometer fully counter clockwise (for minimum output current).
- 5) Set the Arm of the Follower Arm Pot. on the FULL roll. Turn on the A.C. power to the supply.
- 6) Turn the SPAN MAX. potentiometer clockwise until the power supply output current equals the value in Step 2.
- 7) With Pointer opposite the 0% mark, the power supply output should be zero. If current is not zero, turn the SPAN MIN. potentiometer counter-clockwise until output current is zero. (The roll will probably need to be removed for this step.)

TENSION ADJUSTMENTS

For tension adjustments, use the SPAN MAX. potentiometer. To increase tension, turn the potentiometer clockwise.
Note: The output current should always be less than the rated current of the brake (or clutch).

When the Arm is rotated away from the roll for loading/unloading, and the potentiometer is beyond the active range, the output current is zero. (Zero torque.)



Follower Arm Potentiometer & Mini-Follower Arm Potentiometer

SET-UP INSTRUCTIONS FOR THE OPEN POWER SUPPLY, WHEN USING THE FOLLOWER POT.

The Follower Arm potentiometer connects to the Placid Industries power supply, and replaces the % Rated Current potentiometer.

Resistance - 500 ohms
Electrical Angle - 65 degrees
Mechanical Angle - 360 degrees (No mechanical stops)

WIRING (Open Power Supply)

- 1) For safety, turn off A.C. input power & unplug A.C. input wires.
- 2) Unplug the Output Connector from the power supply.
- 3) Loosen the screws securing the 3 wires to the % Rated Current potentiometer, and remove the wires from the connector.
- 4) Connect the 3 wires from the Follower Arm Potentiometer to the connector as shown in Figure 1.
- 5) Refer to the power supply directions for wiring A.C. input power and the brake (or clutch).
- 6) (Optional) Refer to the enclosed directions on wiring a remotely mounted Span Max. potentiometer for remote tension adjustments.

INITIAL SET UP

- 1) Determine the desired web tension. Then calculate the torque required to produce the tension when the roll is full.
 $\text{Torque} = \text{Tension} \times \text{Roll radius.}$
- 2) Determine the current required by the brake (or clutch) to produce the tension by consulting the brake (or clutch) torque curve.
- 3) For safety, disconnect the A.C. power to the power supply.
- 4) Put SWITCH SW2 to position 2. (See the power supply diagram.)
- 5) Slide switch SW3 towards 'Remote to select a remote Span Max. Pot for easy, convenient tension adjustments, -OR- Slide switch SW3 towards the edge of the circuit board to select the on-circuit-board SPAN MAX. pot for tension adjustments.
- 6) Set the Span Max pot (or remote Span Max. pot) fully counter clockwise (for minimum output current).
- 7) Set the arm of the Follower Arm Pot. on the FULL roll. Turn on the A.C. power to the supply.
- 8) Turn the SPAN MAX. potentiometer (or remote Span Max. pot) clockwise until the power supply output current equals the value in Step 2.
(Note: For open power supplies without an ammeter, temporarily connect a portable multi meter in series with the brake (or clutch) to measure the current, as shown in the open power supply directions.
- 9) With the Pointer on the shaft of the Follower opposite the 0% mark, the power supply output should be zero. If current is not zero, turn the SPAN MIN. potentiometer counter-clockwise until output current is zero. (The roll will probably need to be removed for this step.)

TENSION ADJUSTMENTS

For tension adjustments, use the SPAN MAX. (or remote SPAN MAX.) potentiometer. To increase tension, turn the potentiometer clockwise. Note: The output current should always be less than the rated current of the brake (or clutch).

When the Arm is rotated away from the roll for loading/unloading, and the Pointer is outside of the 0% thru 100% marks, the output current is zero. (Zero torque.)



Placid Industries, Inc.

139 Mill Pond Drive, Lake Placid, NY 12946 USA

www.placidindustries.com

Phone 518 523-2422

Fax 518 523-2746

P4-o/5 7-98

98-16841

Follower Arm Potentiometer & Mini-Follower Arm Potentiometer

WIRING A REMOTE TENSION ADJUSTMENT POTENTIOMETER TO AN OPEN POWER SUPPLY

The web tension is varied by adjusting the on-circuit-board Span Max. potentiometer or by a remotely mounted Span Max. potentiometer on the operator's panel.

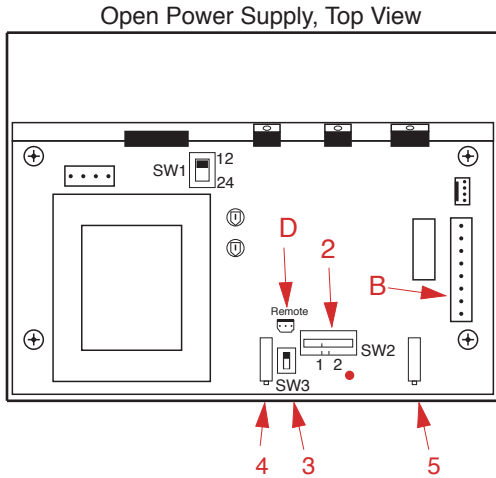

- B. OUTPUT CONNECTOR
 - D. PLUG, 3 prong, for a remote Span Max. Potentiometer, (for conveniently making tension adjustments when using the Follower Arm Potentiometer)
2. SWITCH SW2 - set to position (2)
 3. SWITCH SW3 - to select either the on-circuit-board Span Max. pot. or remote Span Max. potentiometer
 4. SPAN MAX. potentiometer (for tension adjustments)
 5. SPAN MIN. potentiometer.

WIRING THE POTENTIOMETER FOR REMOTE TENSION ADJUSTMENTS

The web tension is varied by adjusting the on-circuit-board Span Max. Pot or by a remotely mounted Span Max pot on the operator's panel. Slide switch SW3 towards the 'Remote' plug, to select the remote pot.

The same 500 ohm potentiometer that is used as the % Rated Current Pot in Manual Mode, can be used as the remote Span Max. pot.

Disconnect the % Rated Current Pot from the Output Connector. Then connect the 3 wires from the pot to the 3 contact receptacle, as shown. Plug the receptacle into 'D', marked 'Remote' on the power supply circuit board.

